

# Operating and Installation Instructions

## BIOCOR Series B 20 / B 32 / B 40



Standard Number 44-03



*Ought to be studied before installing the pump*

Original Instruction

<b>CONTENTS</b>	<b>PAGE</b>
Introduction .....	3
General description of the machine, appropriate use and residual dangers .....	3
Storage .....	3
Codesystem .....	3
Operation in explosion-proof areas .....	4
Technical data .....	5
Performance curves .....	5
Recommended installation .....	7
Installation and operation .....	7
Torque values .....	8
Safety hints .....	8
Additional temperature hints .....	9
Usage of the magnetic ball lifters .....	10
CIP and SIP cleaning .....	10
Disassembly .....	10
Hints for assembly .....	11
Troubleshooting .....	13
Spare part list .....	15
Exploded view .....	16
Dimensions .....	17
Optional equipment .....	18
Stroke counting (code C) .....	18
Diaphragm monitoring (code D) .....	18
3-A design (code 3A-D) .....	19

## Introduction

ALMATEC air-operated diaphragm pumps are constructed according to the state of the art and they are reliable. Imminent danger by operating error or misuse can lead to damages of properties and/or persons. The pumps are to be applied for the intended use and in a safety-related proper condition only.

Each person working on the ALMATEC air-operated diaphragm pumps concerning installation, start-up, handling or maintenance has to read this manual completely and in an attentive way and has to follow all mentioned procedures and safety notes.

## General description of the machine, appropriate use and residual dangers

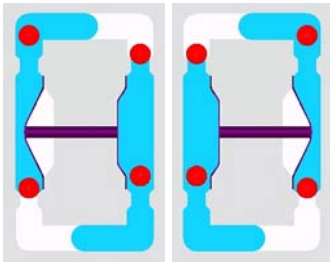

The ALMATEC BIOCOR pumps are oscillating positive displacement pumps and are based on the functional principle of double diaphragm pumps. The basic configuration consists of two external side housings with a center housing between them. Each of the side housings contains a product chamber which is sealed against the center housing by a diaphragm. The two diaphragms are interconnected by a piston rod. Directed by an air control system, the diaphragms are alternately loaded with compressed air so that they move back and forth. In the first figure, the compressed air has forced the left-hand diaphragm towards the product chamber and displaced the liquid from that chamber through the open valve at the top to the discharge port. Liquid is simultaneously drawn in by the right-hand diaphragm, thus refilling the second product chamber. When the end of the stroke is reached, it reverses automatically and the cycle is repeated in the opposite direction. In the second figure, liquid is drawn in by the left-hand diaphragm and displaced by the right-hand diaphragm.

The appropriate use of an Almatec air-operated diaphragm pump of the BIOCOR series refers to the liquid transport taking into account the operation parameter mentioned in this manual and in compliance of the given terms for commissioning, operation, assembly, disassembly and maintenance.

Even if all necessary safety measures described in this manual have been met, a residual danger exists by leakages or mechanical damages. At sealing areas or connections liquid can be released uncontrollably then.

## Storage

In general the ALMATEC pump is delivered operational and packaged. If the unit is not installed right away, proper storage conditions are important for a trouble free operation later. The pump has to be protected from wetness, coldness, dirtying, UV-radiation and mechanical influences. The following storage conditions are recommended:

- Steady ventilated, dust and vibration free storage room
- Ambient temperature between 15°C and 25°C with a relative humidity below 65%
- Prevention of direct thermal influences (sun, heating)

## Codesystem

The ALMATEC Maschinenbau GmbH is certified as a modern, quality-orientated enterprise according to DIN EN ISO 9001:2008 and 14001:2005. Before release for dispatch, any pump of the BIOCOR series has to undergo an extended final control. The performance data registered during this are archived in our records and can be read back at any time.

As a general rule in the countries of the EU only such machines are allowed to take into operation, which are determined to meet the regulations of the EU machinery directive, the harmonized standards, European standards and the respective national standards. Hence the operator has to verify whether the ALMATEC pump manufactured and delivered properly according to the customers order meets the mentioned requirements.

Therefore make sure, before putting the pump into operation, that the pump and the used materials of construction are suitable for the provided application and the installation site. To check this, the exact pump code is required. This code, the serial number and the year of construction are noted on the identification plates on the pump itself.

Example for a pump code:

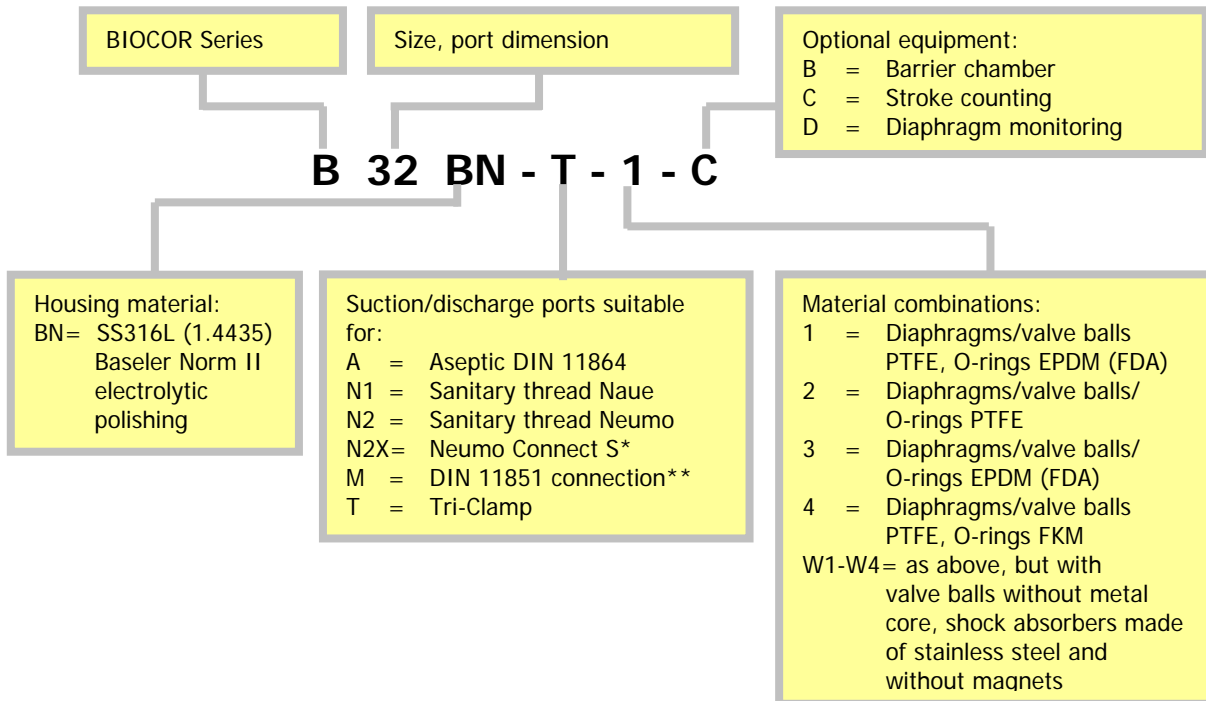

\* Not available on models marked with 3-A symbol.

\*\* For models supplied marked with 3-A symbol, gaskets from SKS components shall be used in combination with suitable rubber materials.

The number in brackets, which is added to every part mentioned in the following explanations, refers to its position in the spare part list and the exploded view.

### Operation in explosion-proof areas and for inflammable liquids (Reg.-No. PTB: 03 ATEX D004)

For inflammable liquids as well as for applications in explosion-proof areas, BIOCOR pumps have to be grounded to one of the M6 tapping holes located in the frame [7]. All other housing parts are connected in a conductive way, therefore it is not necessary to ground single parts.

Grounded BIOCOR pumps are suitable to be used in explosion areas of the category 2 and 3, atmosphere G/D, which are liable to the 94/9/EG. Conductive diaphragms (liquid side) are applicable without restrictions for transferring liquids of any explosion-group.

When using non-conductive diaphragm materials, the following exemplary protection measures have to be respected:

- The pump is always used for the transfer of exclusively fluids which are conductive or soluble in water or
- Dry-running is avoided by action steps within the facility and/or its control or
- The system is inertised in case of dry running by nitrogen, water, carbon dioxide etc. when the fluid transfer ends.

Piping systems and product connections have to be grounded separately. To avoid ignition hazards the formation of dust deposits on the pumps must be prevented. In explosion proof areas repair working only after careful inspection of the practicability and only with appropriate tools. For the marking according to 94/9/EG please see the attached conformity declaration. For the ATEX marking according to 94/9/EG please see the attached conformity declaration and the according pump label.

CIP and SIP cleaning processes, which briefly exceeding the max. surface temperature T80°C, have to be checked concerning its ATEX permissibility by the operator.

Technical data	B 20	B 32	B 40
Dimensions (mm)	see page 17	see page 17	see page 17
Nominal port size (please see page 18)	-	-	-
Air connection BSP	1/4"	1/4"	1/2"
Weight kg (lbs)	12 (27)	26 (57)	67 (147)
Max. particle size of solids mm (")	3 (0.12)	5 (0.20)	9 (0.35)
Suction lift, dry mWC (')	2 (6.6)	2,5 (8.2)	3 (9.8)
Suction lift, wet mWC (')	9 (29.5)	9 (29.5)	9 (29.5)
Max. driving and operating pressure bar (psig)	7 (100)	7 (100)	7 (100)
Max. operating temperature °C (°F)	80 (176)	80 (176)	80 (176)
Theoretical displacement volume per single stroke (l)	0.11	0.31	0.9
Sound pressure level acc. to DIN 45635, part 24, depending on the operating data [dB (A)]:			
driving pressure 3 bar	68-71	69-71	76-78
driving pressure 5 bar	73-75	71-75	77-80
driving pressure 7 bar	74-78	73-76	78-82

### Performance curves

The data refer to water (20°C), without using of a pulsation dampener.

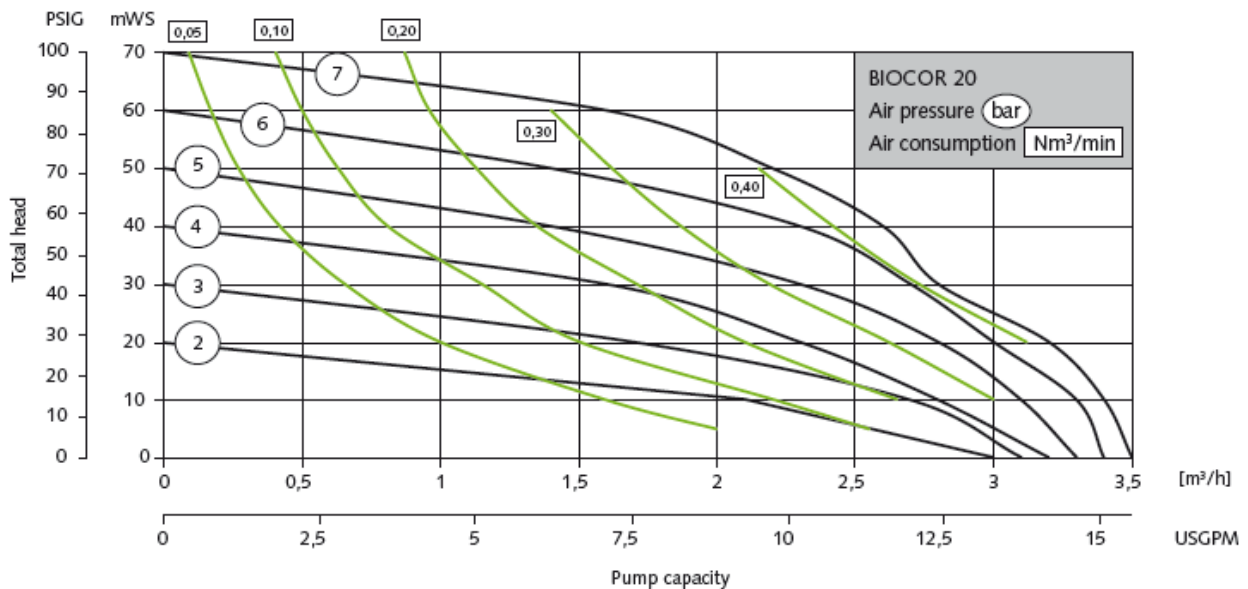

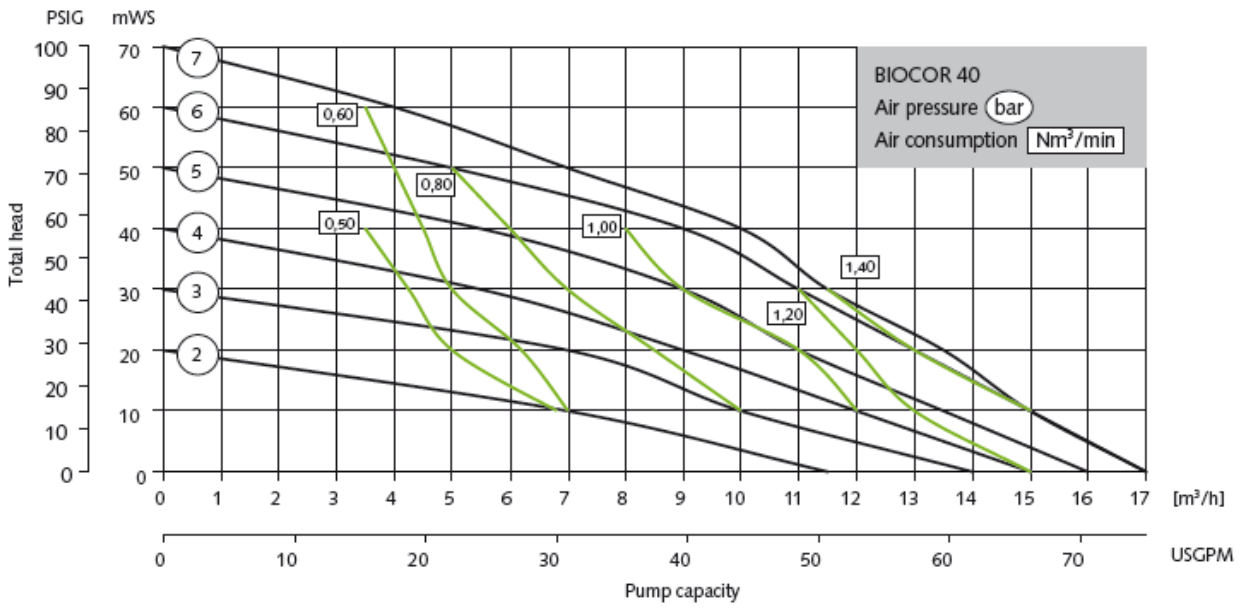
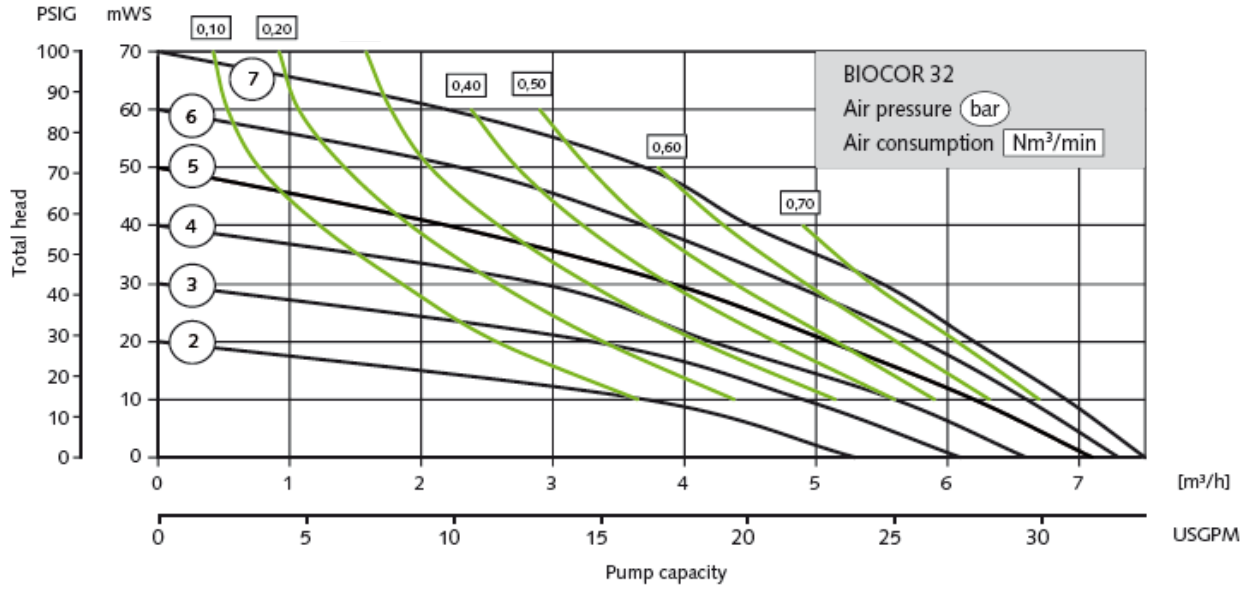

## Recommended installation

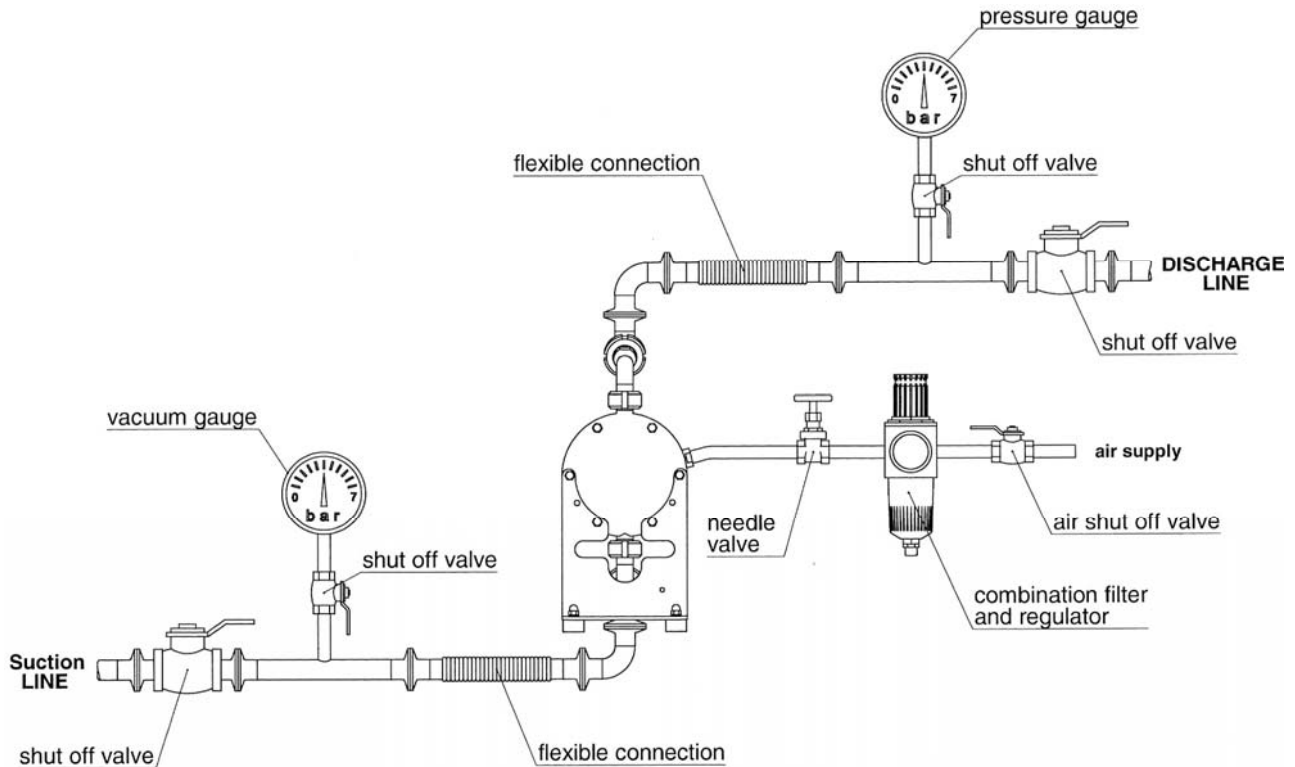

## Installation and operation

In general, the pump has to be connected load free. Neglecting this causes leakage and maybe even damages. To avoid vibrations, pulsation dampers and compensators are recommended. Before connecting the pump, take the yellow blind plugs out of the suction and discharge connections [4,6] as well as the air inlet [23].

The operator is responsible for an adequately stability and an appropriate fixation of the piping according to the state of the art. To facilitate the installation and maintenance shut off valves should be installed right before and after the pump. The nominal width of the connection pipes has to be chosen in accordance to the connections of the pump. A smaller piping can cause cavitation (suction line) as well as a loss of performance (suction and discharge line). In case the pipe is too big, the dry suction capacity of the pump can decrease. Connect the suction line to the lower manifold [4]. Hosepipes should be suitably armoured. A suction line continuously rising will prevent the formation of air locks in the line which would affect the suction lift. The discharge line has to be connected to the upper manifold [4].

The air inlet [23] is located in the middle of the center block [20]. Before installation, make sure that the air supply pipe is free of solids. To supply the pump with driving air sufficiently, the pipe diameter should match the size of the air inlet. Take care that no dirt or particles can intrude into the pump during the connection, as these can accumulate inside the pump and can cause malfunctions. An air filter [22] directly behind the air inlet [23] prevents the entry of bulk particles.

The integrated air control system *PERSWING P*<sup>®</sup> [22] is a precision-control that requires oil-free, dry and clean compressed air for optimal function. If humidity is expected, a water separator or air dryer has to be fitted to protect the pump from blocking by ice. The ideal condition is the dewpoint of air at -20°C. In humid surroundings, icing from the outside may occur despite the driving air is dried. If so, a prolonged waste-air-exhaust (ca. 500 mm by pipe or hose) can be helpful. When installing the pump into boards or cabinets, it has to be ensured that cold air does not get caught behind the muffler. In applications with a tendency to freezing at the waste air exhaust, good experiences in practise have been achieved by pre-heating the driving air to increase the distance to the dew point of the air. Doing so, it has to be considered that the driving air temperature generally may not exceed 50°C to avoid expansion and sticking effects on the air side. This max. air temperature is a well valid when using a compressor producing warm air which is e.g. often true for truck compressors.

The pressure of the driving air should be limited to the amount required to meet the performance needed. Excessive pressure increases both the air consumption and the wear of the pump. The pump is regulated by tuning the flow rate of the air. For a proper operation at the lower performance range the regulation via a needle valve is recommended. An empty pump has to be driven slowly (e.g. via a needle-valve). The pump starts automatically. Pumps of the BIOCOR series are self-priming when dry, thus it is not necessary to fill the suction line of the pump. The suction lift capacity of a liquid-filled pump, however, is much higher. The pump is appropriate for running dry during slow operation. Dry running at high stroke frequency causes premature wear. The pumps can briefly (up to max. one hour) be operated against a closed discharge line. Throttling on the suction side may damage the pump. When the pump operation has been stopped by a closed discharge, the pressure equilibrium of the diaphragms must be ensured. This can be achieved by keeping the pump connected to the air supply pressure; for longer stoppage, the pump must be released from the pressure within the system on both fluid side and air supply side.

### Torque values



Before putting the pump into operation as well as after some hours of operation, the housing bolts [8,9] have to be fixed according to the torque data of the following schedule, as the elements of construction "settle". Fixing the bolts is necessary as well after longer periods of stoppage, at extreme temperature variations, after transport and dismantling the pump. In case of temperature varying between extremes or high temperature difference between the liquid and the surrounding, the housing bolts should be controlled more frequently (interval proposals are available on request).

Pump size	B 20	B 32	B 40
Torque values for housing bolts (Nm)	15	27	20

### Safety hints



- Installation, operation, and maintenance by qualified staff only.
- Before start-up of the pump anyone should acquaint oneself with the explanations of the chapter troubleshooting (see pages 14/15). Only by this the defect quickly can be realized and eliminated in case of trouble. Problems which cannot be solved or with an unknown reason should be passed on to the manufacturer.
- Before any maintenance and service procedures arising on the pump or on the optional equipments, the complete installation has to be turned off and protected against accidental turn on. This is possible by a lockable emergency stop for the air supply of the pump. Additional a danger sign against restart should be attached.
- Pressure tests of the plant a pump is included in may only be carried out with the pump disconnected from the pressure on both ports or by using the pressure the pump develops while operating. The load of a pressure in the plant may damage the pump.
- Pump must not be operated with a positive suction pressure.
- Depending on the conditions of operation, the liquid conveyed might escape from the pump through the muffler in case of a diaphragm rupture (in this case muffler has to be replaced). For further safety requirements the optional equipment diaphragm monitoring and barrier chamber system are recommended.
- In case of a diaphragm rupture, it might be possible for the fluid pumped to intrude into the air side of the pump. In very adverse conditions - e.g. pressure within the fluid system during stopped air supply - the fluid might as well find its way into the air supply lines. To protect other devices like pulsation dampers or even pneumatic valves, it is recommended to protect the air supply line accordingly, e.g. via a non-return valve. This would as well avoid polluting the air supply line.
- The state of the muffler has to be inspected regularly, as a blocked muffler can be forced out of the pump. If this happens, damages of properties and/or persons cannot be excluded.
- If the product tends to settle, the pump has to be flushed regularly. For larger solids a filter has to be installed in the suction line.
- In case of delivery of hot liquids the wetted pump must not standstill for a longer time, because it could lead to temporary leaks in the valve area and to a blockade of the air control system.
- The relevant effective security advises have to be respected.



- Pools of liquid which appear in the near outer area of the pump have to be inspected on danger potential, if necessary safety measures are to be taken.
- Chemical and biological reactions in the product chamber of the pump (mixture of different substances) and the freezing of the liquid have to be avoided.
- Before starting to disassemble the pump, take care that the pump has been emptied and rinsed. Both ports piping are to be closed and drained if applicable. Further the pump has to be cut off from any energy on the air and product side. If the pump is being deported from the plant, a reference about the delivered liquid has to be attached.
- Please respect the relevant additional security advices, if the pump has been used for aggressive, dangerous or toxic liquids (e.g. suitable protective equipment according to the safety data sheet of the liquid). In case of a diaphragm rupture, it is possible that residues of the liquid remain behind the diaphragms, in the area of the air control system and at the muffler, despite of several flushing processes. Hence, appropriate safety equipment according to the safety data sheet of the liquid is indispensable.
- Before putting the pump back into operation, the tightness of the pump has to be checked.
- Pumps of the BIOCOR series must not be submerged.
- Air-operated diaphragm pumps can lead to bruises when lifting, sinking or assembling them. Appropriate accessories and safety equipments are to be used. Big and heavy modules have to be fixed and secured to lifting gears when transporting/replacing them.
- Especially when deliver critical liquids, wear parts, like diaphragms, should be replaced within a preventive maintenance.
- The use of non-original ALMATEC spare parts and structural changes lead to the lapse of the warranty immediately. When operating such a pump, damages of properties and/or persons cannot be excluded.
- The operation of the pump with nitrogen as driving gas is possible. In closed rooms sufficient ventilation must be provided.
- Possible electrical connections (e.g. when using optional equipment with controllers) may be executed by a qualified person only. The regulations of the respective manufacturers are to be followed.
- At any work arising it has to be made sure that no explosive atmosphere can appear. Appropriate safety equipment is recommended.
- Procedure for pump return: According to the requirements of our 14001-certification, every unit which is send to ALMATEC for diagnosis or maintenance reasons has to be accompanied by a filled out decontamination-sheet. Otherwise a processing is not possible. The decontamination-sheet is enclosed to this manual. Please pay attention to the further safety regulations.

### **Additional temperature hints**

The temperature and pressure limitations listed on page 5 are solely based on mechanical temperature limits of the housing material used. Depending on the fluid pumped, the maximum safe operating temperature of the housing material can be reduced significantly.

A general aspect of lower temperatures is, that below 0°C cold-brittling of the elastomers used within the pumps can results in accelerated wear. ALMATEC pumps can therefore be operated safely as well within low-temperature installations: However, with liquids below 0°C accelerated wear of internal parts has to be accepted. Moreover, freezing, bogging or crystallisation of the fluid pumped must be avoided, especially within the pump.

Please consider, that viscosity and specific gravity of most fluids change with temperature (most often increasing at lower temperature). Depending on the application, this fact may not only result in result in a reduced flow rate, the pump may even be unable to prime the thicker and/or “heavier“ fluid any more.

In case of varying application temperatures, the housing bolt tension has to be controlled very thoroughly, as variations like these can change the effective tension of the housing bolts via the different thermal expansion characteristics of single.

## Usage of the valve lifting magnets (sizes B 20 and B 32 with material combination 1 - 4 only)

Valve lifting magnets are attached to B 20 and B 32 BIOCOR pump. These can be mounted at the position location of the four ball valves from the outside to the pump housing. The ball valves are raised up magnetically out of their seats and the pump is drained entirely without having to be dismantled.



The used magnets are strong NdFeB magnets. Therefore an appropriate safety distance (500 mm) must absolutely be kept to all devices and objects, which can be damaged by magnetism or impaired in their function. This applies in particular to persons with cardiac pacemakers; the manufacturer data of the implant are to be considered. Further endangered devices and objects: Credit cards, EC cards, hearing aids, data media, televisions, monitors, computers, video tapes, mechanical clocks, and loudspeakers. Colliding of the magnets is to be avoided, due to their brittleness these can break.

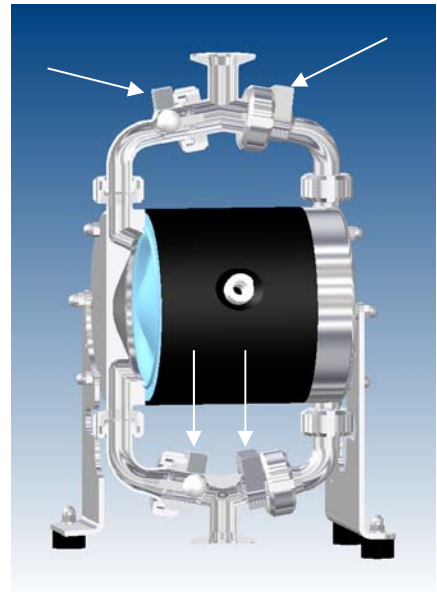

Procedure: Pump has to run slowly; take the magnets out of the box separately and put them individually on the pump (positions see arrows in image on the right). The pump runs dry after a few strokes and can be turned off. Pull the magnets individually off the pump and put them with the magnet part first back into the box.

## CIP and SIP cleaning

Basic condition for the delivery of hygienic perfect and high-quality liquids is a clean pump. The construction of the EHEDG certified BIOCOR pumps permits the CIP as well as the SIP cleaning. Despite the general restriction of temperature of 80°C a brief operating (max. 30 minutes) to 130°C for purification processes is permitted, in these cases the pump must run slowly (e.g. sterilization with steam). If a cleaning liquid is used, this should be sucked by the pump itself without external pressure in the system. For explosion proof areas please see the explanations on page 4.



## Disassembly

When dismantling a pump the mentioned procedures and safety notes on the pages 7-9 have to be considered generally. The general design of the ALMATEC BIOCOR pumps is simple. A plastic tool designed for the mounting of the air-valve [22] is delivered along with every pump. Further special tools are not required. Please find the part number for any part in the spare part list.

First unscrew the muffler [25] out of the center block [20]. Loosen the four union nuts of the suction and discharge ports [4,6] with a hook wrench (figure 11.1), but do not unscrew complete. Loosen the two union nuts, which connect the two pipe bends discharge side [5] with the pump housings [1], to take off the whole discharge side of the pump. Remove O-rings pump housing [2]. Lay the pump on its back and unscrew the nuts of the housing bolts [8,9] on one side using a socket wrench and take off the frame [4]. Loosen the two union nuts, which connect the two pipe bends suction side [3] with the pump housings [1], to take off the whole suction side of the pump. Remove O-rings pump housing [2] followed by the pump housing [1] itself. So the complete discharge side, one pump housing [1], one frame [7] and the complete suction side are dismantled (figure 11.2). Turn off the union nuts at the suction and discharge sides, so that the pipe bends [3,5] and the suction and discharge ports [4,6] are separated. Remove valve stops [17], O-rings valve stop [19] and valve balls [16].



figure 11.1



figure 11.2



figure 11.3

Work carefully to ensure that the sealing surfaces in contact to the diaphragms are not damaged. Screw one diaphragm [15] left-turning off the shaft [13]. Carefully pull out the housing bolts [8,9], so the second pump housing [1] and the second frame [7] are also dismantled. Take the other diaphragm [15] along with the shaft [13] out of the center block [20]. Unscrew the set screws shaft [14] off the diaphragms [15] (figure 11.3). Remove piston rings and O-rings of the shaft piston rings [21] from their grooves carefully (figure 11.4); do not damage the edges in the center block [20]. A re-assembly of the same piston rings is impossible, they have to be replaced. Unscrew the air inlet [23] and the air filter [24] out of the center block [20]. To remove the *PERSWING P*<sup>®</sup> air control system [22], screw off both end caps using the plastic mounting tool supplied with the pump (figure 11.5). Take out main and pilot piston. Push out the air valve housing with the mounting tool turned around (figure 11.6).



figure 11.4



figure 11.5



figure 11.6

### Hints for assembly

The re-assembly of the components is principally carried out vice-versa to the dismantling. Here are some additional hints.

For the installation of the *PERSWING P*<sup>®</sup> [22] air control system, first screw in one end cap flushly into the center block [20]. Turn the center block [20] and insert one of the six O-rings air-valve housing [29] into the end cap from the inside of center block [20]. Moisture the four O-rings [29] of the air-valve housing with a bit of water and push the housing into the center block [20] using the mounting tool. Take care that it slips in softly. Do never insert the housing violently with a hammer. In case the housing cocks or hardly gets in, take it out again completely and start again. Insert the main piston and the pilot piston. Lay the sixth O-ring [29] on the edge of the air valve housing and screw in the second end cap.



figure 12.1

To assemble a new piston ring of the shaft piston ring [21], carefully shape them like kidneys with locking ring pliers and insert the rings into the grooves in the center block [20] (figure 12.1); completely press the rings into the grooves smoothly using some round tool.

Screw the set screws shaft [14] into the diaphragms [15] and tighten them. Screw one diaphragm [15] with set screw shaft [14] into the shaft [13], insert it into the center block [20], adjust the bores in the center block [20] to the diaphragm (turn slightly backwards if necessary) and fix it with the housing bolts [8,9] (figure 12.2), pay attention to the two different length of the housing bolts [8,9] (B20/B32 only). The sealing surfaces of the diaphragms [15] and the pump housings [1] have to be absolutely clean and undamaged; mere small scratches can cause leaking (if necessary, smoothen the housing surfaces carefully with fine sandpaper).

Push the pump housing [1] onto the housing bolts [8,9] (figure 12.3), pay attention to the right direction of the suction and discharge side of the pump housing [1]. The hole at the suction side has nearly a right angle, the discharge one is obviously flatter. Push the discs onto the lower and longer housing bolts [9] and install the frame [7] (figure 12.4).



figure 12.2



figure 12.3



figure 12.4

Screw the second diaphragm [15] into the shaft [13], adjust with the bores in the center block [20] (turn slightly backwards if necessary) and carefully push the housing bolts [8,9] complete through the center block [20]. Install the second pump housing [1], pay attention to the flow direction again. If necessary carefully compress the pump housings [1] and the center block [20] by using a screw clamp. Mount the second frame [7] (do not forget the disc) and tighten the housing bolts [8,9] only loose.

Spray the threads of the ports [4,6] and the pump housing [1] with Teflon-Spray. Carefully insert O-rings valve stop [17] into the suction [4] and discharge ports [6] as well as into the pipe bends [3,5] (buckling has to be avoided). On the suction side place the ball valves [16] in the suction port [4] and on the discharge side in the pipe bend [5]. To install the valve stops [17] insert the pin of the valve stop [17] in the appropriate notch of suction [4] or discharge port [6] (figure 12.5). Screw the union nuts of the pipe bends [3,5] on the suction [4] and discharge ports [6] loose by hand



figure 12.5

Insert O-rings pump housing [2]. Screw the complete pre-installed suction and discharge sides with the corresponding union nuts onto the pump housings [1] loosely. First lightly screw housing bolts [8,9], then tightly all eight union nuts with a hook wrench. Now fix the housing bolts [8,9] crosswise evenly according to the given torque values (see page 8) until the pump housings [1] are situated on the center block [20]. Any further tightening of the bolts does not improve sealing but can deform the housing! Finally screw all eight union nuts again with a hook wrench.

Before putting the pump back into operation, the tightness of the pump has to be checked.

## Troubleshooting

Malfunction	Possible Reason	Solutions/Remarks
pump does not operate	no air supply air supply line blocked/closed muffler blocked working chambers blocked air control system defective discharge line blocked/closed	open air supply clean/open air supply clean/replace muffler remove blockage replace air valve system clean/open line
pump operates unsteadily	piston rings worn air control system worn diaphragm rupture air control system soiled ball valve blocked icing	replace piston rings replace air control system replace diaphragm, clean pump clean/replace air control system cleaning, removal of bulk particles improve air processing
air within liquid	suction line leaky container with liquid empty diaphragm rupture cavitation	seal suction line fill/new container replace diaphragm adapt suction lift, possibly install suction pressurised air chamber
insufficient discharge pressure	insufficient pressure/amount of driving air air supply line leaky air control system leaky ball valve worn more air consuming components	increase air supply check/repair air supply replace air control system check/replace ball valve increase pressure/amount of air
output decreases	air control system soiled icing air pressure drop suction line/inlet strainer soiled discharge line/outlet strainer soiled muffler blocked ball valve worn change in viscosity more air consuming components	clean/replace air control system improve air processing: dryer/filter ensure sufficient supply of air cleaning cleaning replace the muffler replace valve change back/adjust pump increase pressure/amount of air
pump stops itself	icing of the air control system air pressure too low air pressure drop discharge line blocked air filter blocked valve closed air control system defective wear/leaking of air control system diaphragm rupture ball valve blocked/worn	improve air processing: dryer/heater etc. increase air pressure ensure sufficient air supply clean discharge line clean air filter open valve replace air control system replace air control system replace diaphragm, clean pump clean/replace ball valve

Malfunction	Possible Reason	Solutions/Remarks
pumps operates, however suction capacity insufficient	<p>pump operates too fast operation beyond physical limits cavitation</p> <p>operation beyond pump capacity</p> <p>air cushion within suction/discharge line</p> <p>dry suction against discharge pressure</p> <p>valve filter within suction line closed</p> <p>valve filter within discharge line closed</p> <p>container with liquid empty</p> <p>vacuum inside the container</p> <p>wear of the check valves</p> <p>suction line leaky</p> <p>suction line blocked</p> <p>air pressure cushion at discharge</p> <p>ball valve blocked</p>	<p>start more slowly</p> <p>adjust installation</p> <p>check installation, check temperature, cool down</p> <p>adjust installation resp. install bigger pump</p> <p>bleed the line</p> <p>wet pump, start without pressure</p> <p>open valve/clean filter</p> <p>open valve/clean filter</p> <p>fill/new container</p> <p>bleed container</p> <p>replace valves</p> <p>seal suction line</p> <p>clean suction line</p> <p>bleed discharge line</p> <p>clean/replace valve</p>
insufficient suction capacity after pump repair	connections tighten incompletely	tighten/seal connections, clean sealing area
diaphragm overstrained	<p>pressure within the plant/system</p> <p>inadmissible vacuum</p> <p>icing</p>	<p>ensure that pressure is only developed by the pump itself, check plant/valves, replace diaphragms</p> <p>check suction line, open valve</p> <p>improve air processing</p>
leaking between housing parts	<p>housing bolts loosened</p> <p>diaphragms attacked chemically</p> <p>diaphragms overstrained</p> <p>tension installation/pipework</p>	<p>disassemble the pump, clean sealing area, tighten housing bolts according to the torque values</p> <p>replace diaphragms</p> <p>replace diaphragms</p> <p>loosen, eliminate tension, use of a compensator</p>
muffler grey	driving air too humid, icing	improve quality of driving air
muffler black	soiled, oily air	improve quality of driving air, install sensitive filter in suction line
pump is connected to air but does not operate	<p>air control system blocked</p> <p>bulk particles/dirt</p> <p>chemical influence (O-rings swollen)</p> <p>valve closed in discharge line</p>	<p>clean/replace air control system</p> <p>clean pump, replace necessary parts, improve air quality</p> <p>check, replace damaged parts</p> <p>open valve</p>
liquid leaves the pump via the muffler	diaphragm rupture	replace diaphragms, clean pump

Spare Part List				B 20	B 32	B 40
Item	Pc.	Description	Material	Part number	Part number	Part number
1	2	Pump housing	SS 316 L	5 20 140 40	5 32 140 40	5 40 140 40
2	4	O-ring, pump housing*	EPDM (FDA)	9 17 557 73	9 23 668 73	9 35 594 73
	4	O-ring, pump housing*	PTFE	9 17 557 60	9 23 668 60	9 35 594 60
	4	O-ring, pump housing*	FKM	9 17 557 94	9 23 668 94	9 35 594 94
3	2	Pipe bend, suction side	SS 316 L	5 20 138 40	5 32 138 40	5 40 138 40
4	1	Suction port, code A (DIN 11864)	SS 316 L	5 20 441 40	5 32 441 40	5 40 441 40
	1	Suction port, code N1 (Naue)	SS 316 L	5 20 041 40	5 32 041 40	5 40 041 40
	1	Suction port, code N2 (Neumo)	SS 316 L	5 20 141 40	5 32 141 40	5 40 141 40
	1	Suction port, Code N2X (Neumo Connect S)	SS 316 L	5 20 541 40	5 32 541 40	5 40 541 40
	1	Suction port, code M (DIN 11851)	SS 316 L	5 20 241 40	5 32 241 40	5 40 241 40
	1	Suction port, code T (Tri-Clamp)	SS 316 L	5 20 341 40	5 32 341 40	5 40 341 40
5	2	Pipe bend, discharge side	SS 316 L	5 20 139 40	5 32 139 40	5 40 139 40
6	1	Discharge port, code A (DIN 11864)	SS 316 L	5 20 442 40	5 32 442 40	5 40 442 40
	1	Discharge port, code N1 (Naue)	SS 316 L	5 20 042 40	5 32 042 40	5 40 042 40
	1	Discharge port, code N2 (Neumo)	SS 316 L	5 20 142 40	5 32 142 40	5 40 142 40
	1	Discharge port, Code N2X (Neumo Connect S)	SS 316 L	5 20 542 40	5 32 542 40	5 40 542 40
	1	Discharge port, code M (DIN 11851)	SS 316 L	5 20 242 40	5 32 242 40	5 40 242 40
	1	Discharge port, code T (Tri-Clamp)	SS 316 L	5 20 342 40	5 32 342 40	5 40 342 40
7	2	Frame	1.4404	5 20 143 23	5 32 143 23	5 40 143 23
8	2	Housing bolt, cpl., short	1.4301	5 20 154 22	5 32 154 22	-
9	4**	Housing bolt, cpl., long	1.4301	5 20 156 22	5 32 156 22	5 40 156 22
10	4	Shock absorber	EPDM	1 15 022 78	1 15 022 78	1 40 022 78
10a	4	Shock absorber	1.4301*****	1 15 022 22	1 15 022 22	1 40 022 22
11	4**	Disc, DIN 125	PTFE	9 06 151 60	9 06 151 60	9 08 151 60
12	4	Nut, DIN 1587	1.4305	9 06 106 22	9 06 106 22	9 06 106 22
13	1	Shaft	1.4301	5 20 145 22	5 32 145 22	5 40 145 22
14	2	Set screw, shaft, DIN 913	1.4305	9 10 220 22	9 12 221 22	9 16 222 22
15	2	Diaphragm*	PTFE	1 15 031 67	1 25 031 67	1 40 031 67
	2	Diaphragm*	EPDM (FDA)	1 15 031 73	1 25 031 73	1 40 031 73
16	4	Valve ball*	EPDM metal core (FDA)***	1 15 032 82***	1 25 032 82***	1 40 032 73
	4	Valve ball*	PTFE metal core***	1 15 032 89***	1 25 032 89***	1 40 032 60
17	4	Valve stop	SS 316 L	5 20 044 40	5 32 044 40	5 40 044 40
18	4	Set screw, DIN 7	1.4301	9 02 401 22	9 02 401 22	9 02 401 22
19	8	O-ring, valve stop*	EPDM (FDA)	9 23 668 73	9 37 528 73	9 58 525 73
	8	O-ring, valve stop*	PTFE	9 23 668 60	9 37 528 60	9 58 525 60
	8	O-ring, valve stop*	FKM	9 23 668 94	9 37 528 94	9 58 525 94
20	1	Center block	PE conductive	5 20 053 56	5 32 053 56	5 40 053 56
21	2	Shaft piston ring, cpl.	PTFE	1 15 041 64	1 25 041 64	1 40 041 64
22	1	PERSWING P® air control system, cpl.	PETP	5 20 101 84	5 20 101 84	5 40 101 84
23	1	Air inlet	PETP	1 15 047 84	1 15 047 84	1 40 047 84
24	1	Air filter	PE	1 15 043 51	1 15 043 51	1 40 043 51
25	1	Muffler	PE	1 15 244 51	1 15 244 51	1 40 244 51
29	6	O-ring, air valve housing****	NBR	9 35 504 71	9 35 504 71	9 46 515 71
30	4	Valve lifting magnet*****	1.4301/NdFeB	5 20 046 22	5 32 046 22	-

\* depends on the material combination (1 - 4 or W1 - W4)

\*\* B 40: 8 pieces

\*\*\* B 40: Valve balls without metal core; material combinations W1 - W4 valve balls without metal core: part number ending 73 instead of 82 (for EPDM valve balls) and 69 instead of 89 (for PTFE valve balls)

\*\*\*\* included in item 22

\*\*\*\*\* not for B 40 and material combinations W1 - W4

\*\*\*\*\* for material combination W1-W4 only

**Please see page 4 for explanation of the pump code. When ordering please state the serial number of the pump. For special constructions of the Biocor pump (for example X01 as code ending) please see separate spare part list.**

Exploded view

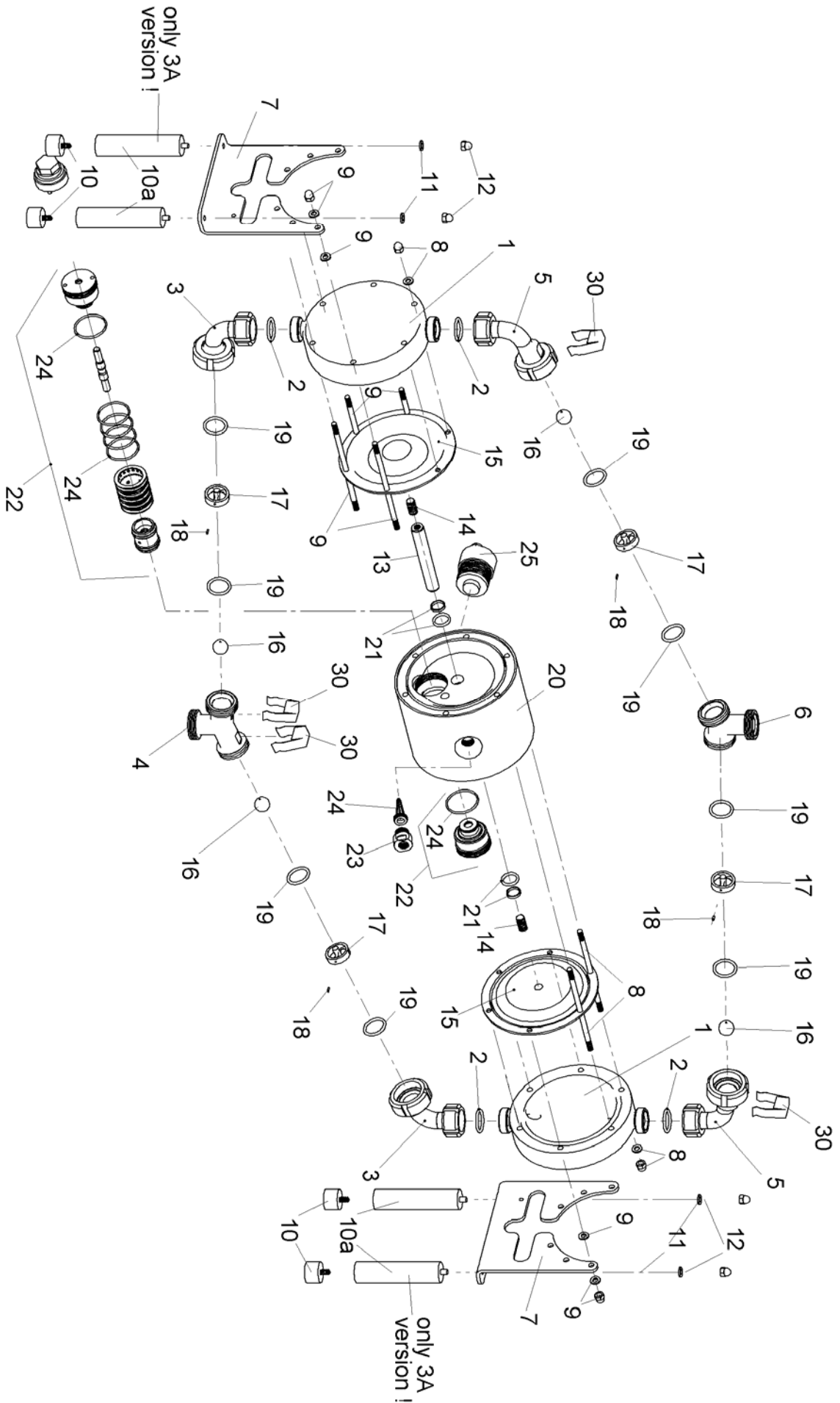



**Dimensions (in mm)**

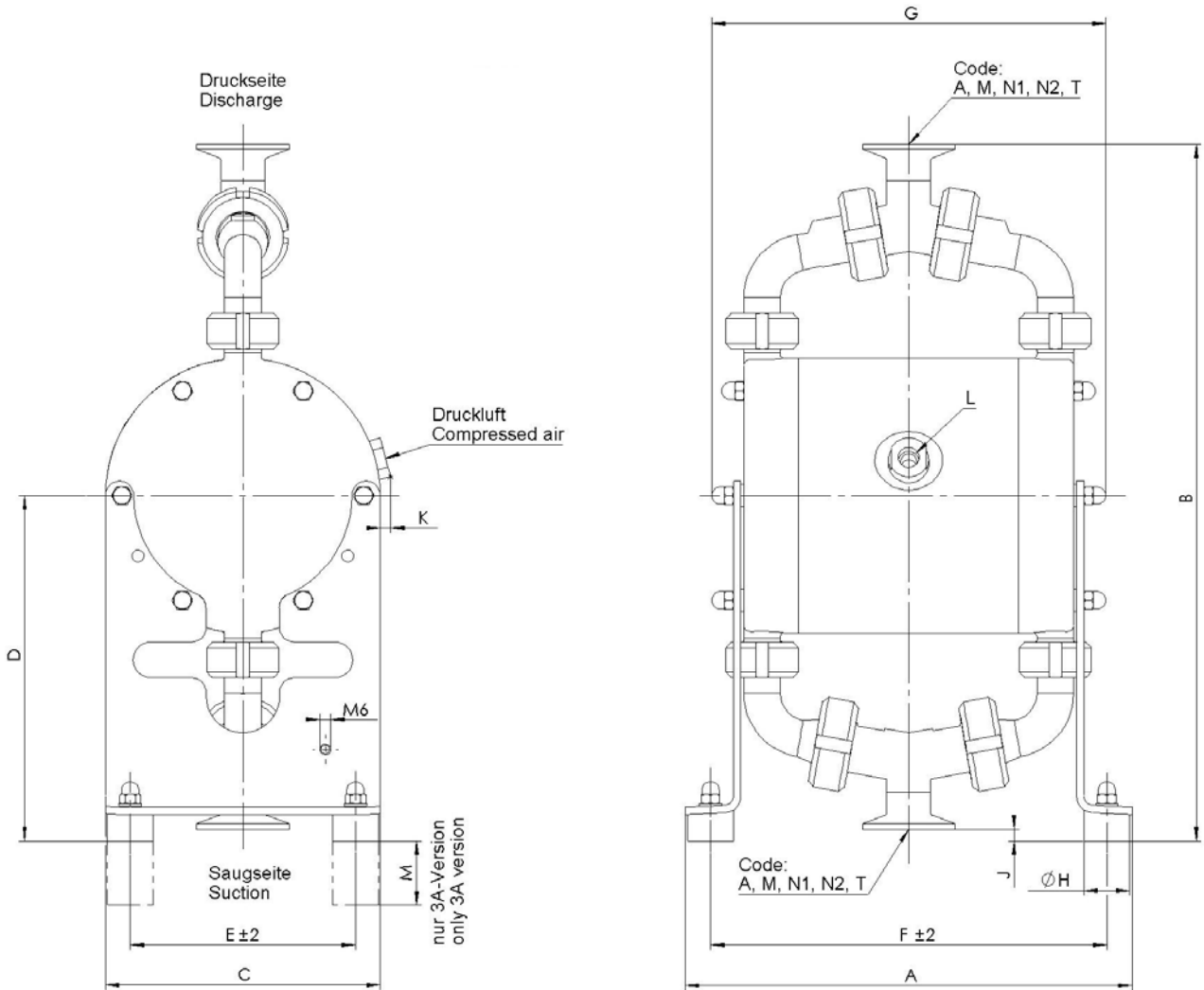

	A	B*	C	D	E	F	G	H	J*	K	L	M
<b>B 20</b>	244	381	150	189	123	216	216	25	6,5	6	R 1/4"	105
<b>B 32</b>	284	484	200	246	173	256	261	25	17,5	-	R 1/4"	105
<b>B 40</b>	462	681	270	335	228	419	401	40	6	-	R 1/2"	-

	<b>Code A (DIN 11864)</b>	<b>Code M** (DIN 11851)</b>	<b>Code N1</b>	<b>Code N2</b>	<b>Code T</b>
<b>B 20</b>	Rd 44 x 1/6" (DN 20)	Rd 44 x 1/6" (DN 20)	M 36 x 2 (DN 20)	M 36 x 2 (DN 20)	1" Tri-Clamp
<b>B 32</b>	Rd 58 x 1/6" (DN 32)	Rd 58 x 1/6" (DN 32)	M 52 x 2 (DN 32)	M 52 x 2 (DN 32)	1 1/2" Tri-Clamp
<b>B 40</b>	Rd 65 x 1/6" (DN 40)	Rd 65 x 1/6" (DN 40)	M 56 x 2 (DN 40)	M 56 x 2 (DN 40)	2" Tri-Clamp

\*Code N2X (Neumo Connect S, not available on models marked with 3-A symbol):

B 20: DN 20; the measure of "B" changes to 433 mm, suction port protrudes 20 mm over the shock absorbers (measure of "J" is dropped)!

B 32: DN 32; the measure of "B" changes to 546 mm, suction port protrudes 14 mm over the shock absorbers (measure of "J" is dropped)!

\*\* For models supplied marked with 3-A symbol, gaskets from SKS components shall be used in combination with suitable rubber materials.

## Optional equipment

For special requirements ALMATEC pneumatic double diaphragm pump of the series BIOCOR can be furnished with several optional equipments. The pump code informs, which of these are included in the pump (see page 4). For the barrier chamber system (option code BS) a separate manual is available.

### Stroke counting (option code C)

A sensor integrated in the center block [20] of the pump to monitor the movement of a diaphragm [15] without direct contact.

The stroke counting system is available in four variations:

- C 2            Stroke sensor (Namur), also for explosion proof zone
- C 3            Stroke counting system complete with sensor and stroke counter
- C 4            Stroke counting system complete with sensor, stroke counter and controller for explosion proof zone
- C 9 / C 10    Stroke counting pneumatical (please see additional information on a separate sheet)

In case only the sensor is included (code C 2), it has to be connected to an existing controller. For applications an explosion-proof device is required for (code C 4) the intrinsically safe controller has to be installed between the sensor and the counter. The wiring diagram and technical data can be found on the electric units themselves.

For further details, please refer to the data delivered by the manufacturers of the components.

Spare Parts Stroke counting					B 20	B 32	B 40
Code	Item	Pc.	Description	Material	Part No.	Part No.	Part No.
C 2	20	1	Center block for sensor	PE conductive	5 20 153 56	5 32 150 56	5 40 150 56
			Center block, sensor, barrier chamber	PE conductive	1 15 340 55	1 25 340 55	-
	50	1	Stroke sensor, Namur	diverse	1 00 072 99	1 00 072 99	1 00 072 99
C 3			as C 2, but additional:				
	-	1	Clamp amplifier	diverse	1 00 171 99	1 00 171 99	1 00 171 99
	-	1	Stroke counter	diverse	1 00 071 99	1 00 071 99	1 00 071 99
C 4			as C 2, but additional:				
	-	1	Controller	diverse	1 00 370 99	1 00 370 99	1 00 370 99
	-	1	Stroke Counter	diverse	1 00 071 99	1 00 071 99	1 00 071 99

### Diaphragm monitoring system (option code D)

A capacitive diaphragm sensor is mounted in the muffler [25] of the pump, which registers any liquid approaching the sensor, no matter whether the liquid is conductive or not. Hence, a fast reaction to a damage of a diaphragm becomes possible. However, it has to be considered, that the diaphragm monitoring possibly cannot prevent that liquid can leave the pump via the muffler. For higher safety requirements the ALMATEC barrier chamber system (optional equipment code BS) is recommended. In case of humid surrounding air a false alert may occur despite operating the pump with dried compressed air.

The diaphragm monitoring system is available in two variations:

- D 1            Diaphragm sensor (Namur), also for explosion proof area
- D 3            Diaphragm monitoring system complete with sensor and controller

The diaphragm sensor can either be connected to an existing controller (code D 1) or to the controller included (code D 3). The wiring diagram and technical data can be found on the controller itself.

For further details, please refer to the data delivered by the manufacturers of the components.

Spare Parts Diaphragm Monitoring					B 20	B 32	B 40
Code	Item	Pc.	Description	Material	Part No.	Part No.	Part No.
D 1	51	1	Diaphragm sensor, Namur	diverse	1 00 773 99	1 00 773 99	1 00 773 99
D 3	51	1	Diaphragm sensor, Namur	diverse	1 00 773 99	1 00 773 99	1 00 773 99
	-	1	Controller	diverse	1 00 370 99	1 00 370 99	1 00 370 99

### 3-A design (option code 3A-D)



Standard Number 44-03

BIOCOR pump sizes B20 and B32 with the material combination 2 or 4 equipped with the option D (diaphragm monitoring, see page 18) are licensed to display the 3-A symbol. Please pay attention to the following additional hints:

- Maintenance interval**  
 ALMATEC suggest following minimum maintenance intervals and processes for the diaphragms and leak detection sensor:  
 By using the pump 24 hours a day/7 days a week the diaphragms and leak detection sensor has to be checked every 3 months. By using the pump in other operating conditions the diaphragms and leak detection sensor has to be checked every 6 months.

- Maintenance process diaphragms**  
 Disassemble the pump as described on page 11. Make an optical check of the condition of the whole pump, especially the condition of the diaphragms (general condition, surface of the product wetted PTFE side, non product wetted EPDM side). For comparison, please use the following pictures:



← image left:  
Good condition



image right →:  
Bad condition

If the diaphragms are in bad conditions, they have to be replaced by new diaphragms.

- Maintenance process leak detection sensor**  
 Unscrew the muffler with the leak detection sensor from the center block of the pump. Stick the sensor into a cup filled with water and check, that the control unit gets a signal from the sensor. If the sensor does not fail, clean the sensor with a smooth cloth and screw the muffler back into the center block. For screwing depth see pictures below.

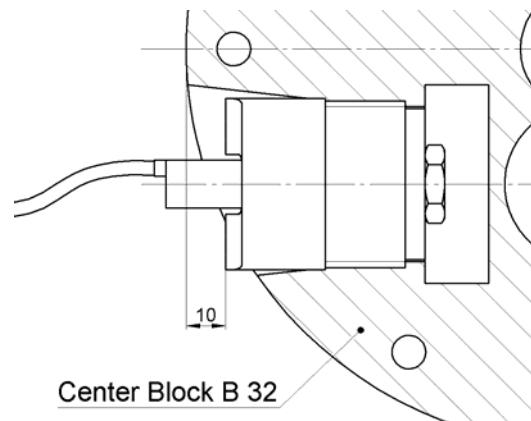
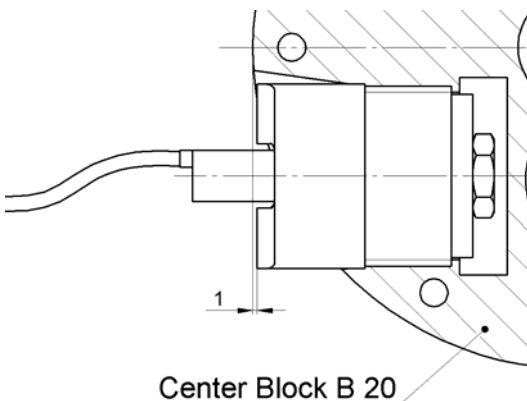

If the sensor fails (no signal to the control unit), the sensor has to be removed from the muffler and to be replaced by a new sensor. Check the new sensor again (as described above). If the sensor gives a signal to the control unit, clean the sensor with a smooth cloth and screw sensor back into the muffler. Screw the muffler back into the center block.

Spare Parts 3-A Design					B 20	B 32	B 40
Code	Item	Pc.	Description	Material	Part No.	Part No.	Part No.
3A-D1	10a	4	Extension shock absorber	1.4301	5 20 022 22	5 20 022 22	5 40 022 22
	51	1	Diaphragm sensor, Namur	diverse	1 00 773 99	1 00 773 99	1 00 773 99
3A-D3	10a	4	Extension shock absorber	1.4301	5 20 022 22	5 20 022 22	5 40 022 22
	51	1	Diaphragm sensor, Namur	diverse	1 00 773 99	1 00 773 99	1 00 773 99
	-	1	Controller	diverse	1 00 370 99	1 00 370 99	1 00 370 99